

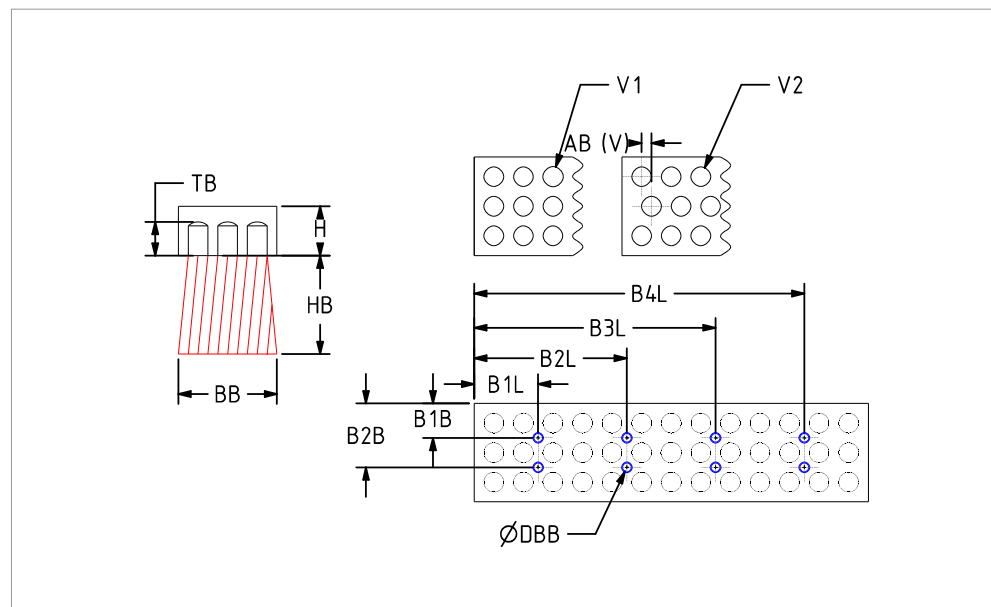

# LEISTENBÜRSTE

## STRIP BRUSH

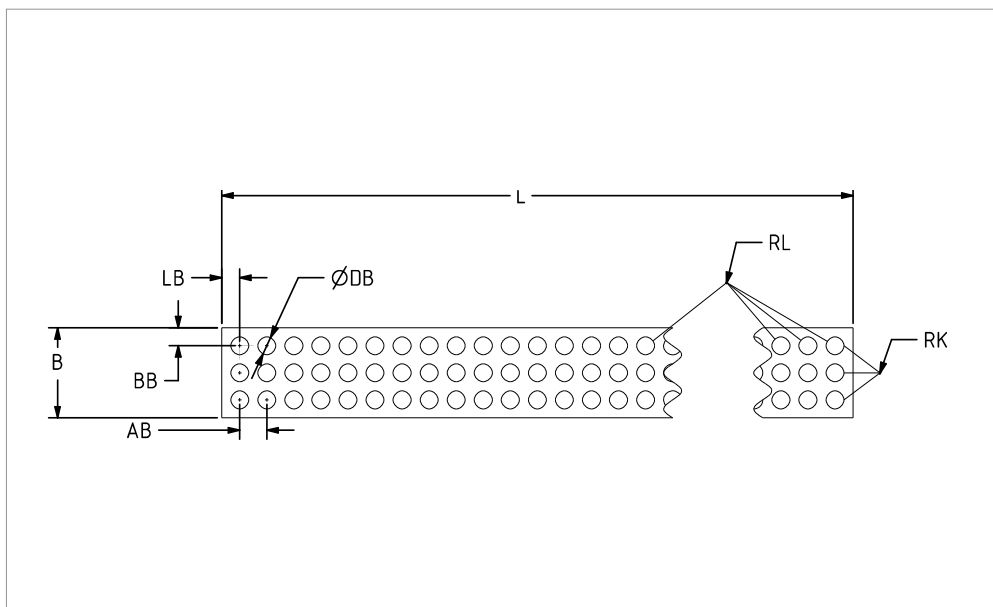

Bitte das Datenblatt digital ausfüllen und die Maßangaben in Millimetern eintragen.

Lf. Nr.	L	B	H	RL	RK	BB	HB	DB	BB	LB	AB	AB (V)	TB
Laufende Nummer Current number	Länge Körper Body length	Breite Körper Body width	Höhe Körper Body height	Anzahl Reihen (Lang) Number of drilling (long range)	Anzahl Reihen (Kurz) Number of drilling (short range)	Breite Besatz Trim width	Höhe Besatz (Sichtbare Länge) Visible height trim	Durchmesser Bohrung Drilling diameter	Beginn Bohrung (kurz) Start drilling short range	Beginn Bohrung (lang) Start drilling long range	Abstand Bohrung Drilling distance	Abstand Bohrung (Bei Versatz) Drilling distance (offset)	Tiefe Bohrung Drilling depth

V1	V2	MK	MB	SB	BA
Bestückung Linear Linear order	Bestückung Versatz Offset order	Material Körper Body material	Material Borste Bristle material	Stärke Borste Bristle diameter	Anzahl Borste (sichtbar) Visible number of bristle

DBB	B1L / B1B	B2L / B2B	B3L / B3B	B4L / B4B	B5L / B5B	B6L / B6B
Bohrdurchmesser (Befestigung) Drilling diameter	Position Bohrung Befestigung Drilling position	Position Bohrung Befestigung Drilling position	Position Bohrung Befestigung Drilling position	Position Bohrung Befestigung Drilling position	Position Bohrung Befestigung Drilling position	Position Bohrung Befestigung Drilling position

Lf. Nr.	ZP	ZM	LT
Laufende Nummer Current number	Zielpreis Target price	Zielmenge Quantity	Liefertermin Date of delivery